

A

B

C

D

E



F

BILL OF MATERIALS

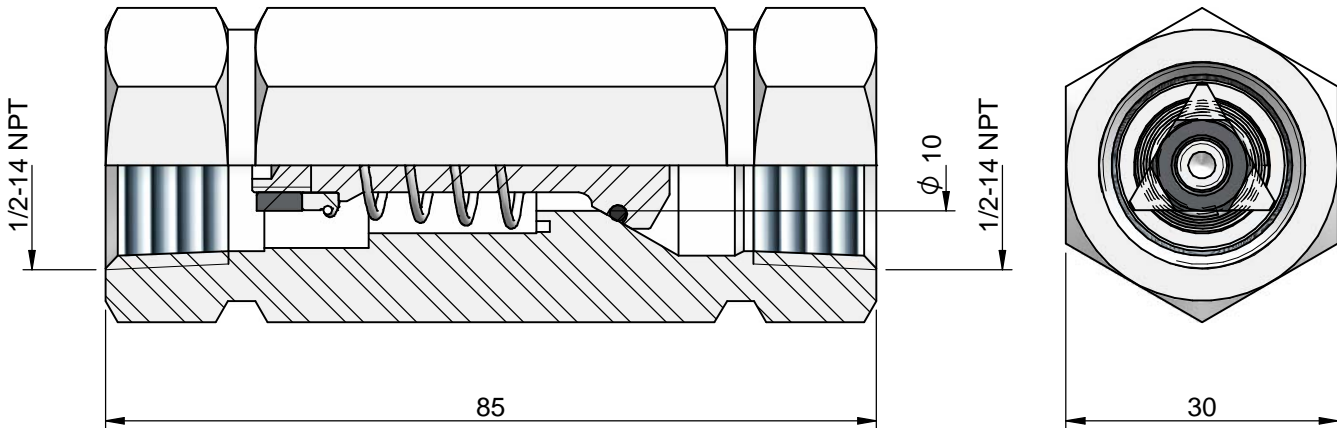
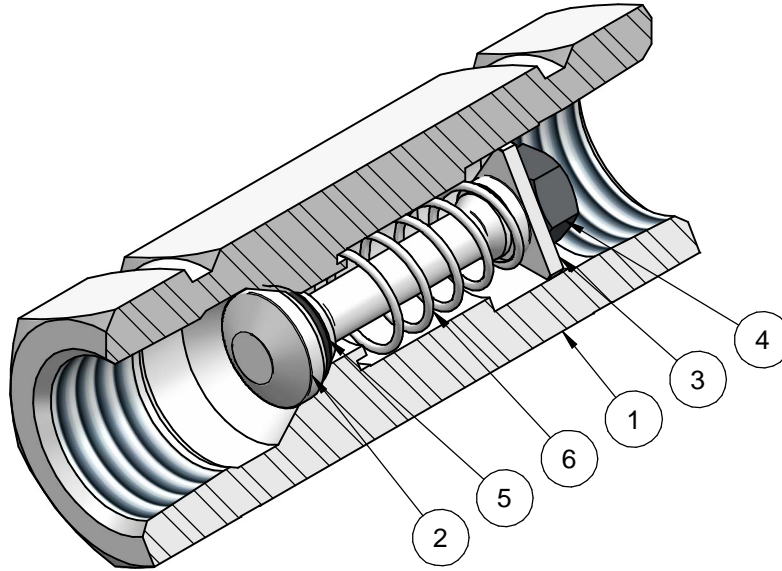
POS.	CODE	DESCRIPTION	MATERIAL	QTY
1	CDVR1.0018-316L	VR1 CHECK VALVE 1/2"N 6.000 PSI - BODY	AISI 316L	1
2	CDVR1.0006-316L	VR1 CHECK VALVE 1/2" - STEM	AISI 316L	1
3	CDVR1.0008-316L	VR1 CHECK VALVE 1/2" - SPRING BUSHING	AISI 316L	1
4	CC010000005	HEXAGONAL NUT M6 - DIN 934	A4	1
5	CC030000008	O-RING 108 8.73x1.78	VITON	1
6	CDVR1.0007-302	VR1 CHECK VALVE 1/2 3.000 PSI - SPRING	X10CrNi18-8	1

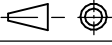

Proprietà riservata a termini di legge. La ditta I.T.E. s.r.l. si riserva la proprietà del seguente disegno, che pertanto non può essere riprodotto né comunicato a terzi, senza esplicita e preventiva autorizzazione.

00	28/04/2021	Tiziano S.	Emissione
REV.	DATA	DIS./PRG.	CAUSALE
	DESCRIZIONE		SCALA
	VR1 CHECK VALVE 6.000 PSI I/O 1/2" NPT-F MAT.: AISI 316L PACKING: VITON		FOGLIO 1 / 1
CATEGORIA PRODOTTO		DISEGNO	
CHECK VALVE		VR106SV8N	
			SOSTITUISCE

A

B

C

D

E

F